



I N S T A L L E R G U I D E



**Roma**

**Model 636**

**(GC No.32 032 05)**

*Please keep in a safe place for future reference*

**Please leave this Installer Guide with the user**

Model 636 is for use with natural gas (G20)

This appliance is for use in the United Kingdom (GB) and the Republic of Ireland (IE) only.

**C U S T O M E R      C A R E**

This Installer Guide gives sufficient details to enable the appliance to be installed and maintained. If further information is required, our **Valor AdviceLine** will be pleased to help.

**Please telephone 0345 626341** (Local call rates apply)

## 1. APPLIANCE DATA

This product uses fuel effect pieces, containing Refractory Ceramic Fibres (RCF), which are man-made vitreous silicate fibres. Excessive exposure to these materials may cause temporary irritation to eyes, skin and respiratory tract. Consequently, it makes sense to take care when handling these articles to ensure that the release of dust is kept to a minimum. To ensure that the release of fibres from these RCF articles is kept to a minimum, during installation and servicing we recommend that you use a HEPA filtered vacuum to remove any dust and soot accumulated in and around the fire before and after working on the fire. When replacing these articles we recommend that the replaced items are not broken up, but are sealed within a heavy duty polythene bag, clearly labelled as RCF waste. This is not classified as “hazardous waste” and may be disposed of at a tipping site licensed for the disposal of industrial waste. Protective clothing is not required when handling these articles, but we recommend you follow the normal hygiene rules of not smoking, eating or drinking in the work area and always wash your hands before eating or drinking.

This appliance does not contain any component manufactured from asbestos or asbestos related products.

The appliance data label is positioned below the burner and is visible when the fire front cover is removed.

<b>Gas</b>	Natural (G20)
<b>Inlet Pressure</b>	20mbar (8in. w.g.)
<b>Input - Max. ( Gross)</b>	6.85kW (23,400Btu/h)
<b>Input - Min. ( Gross )</b>	3.4kW (11,600Btu/h)
<b>Burner injector</b>	Bray Cat.18 Size 420
<b>Burner Test Pressure- Cold</b>	17.3mbar $\pm$ 0.75mbar (7.0in w.g. $\pm$ 0.3in w.g.)
<b>Inlet Pipe Connection</b>	8mm
<b>Pilot &amp; Atmosphere Sensing Device</b>	720A453
<b>Ignition</b>	Piezo Spark
<b>Aeration</b>	Non-Adjustable

## 2. GENERAL INSTALLATION REQUIREMENTS

The installation must be in accordance with these instructions.

For the user's protection, in the United Kingdom it is the law that all gas appliances are installed by competent persons in accordance with the current edition of the Gas Safety (Installation and Use) Regulations. Failure to install the appliance correctly could lead to prosecution. The Council for the Registration of Gas Installers (CORGI) requires its members to work to recognised standards.

In the United Kingdom the installation must also be in accordance with:

- a) All the relevant parts of local regulations.
- b) The current edition of the Building Regulations issued by the Department of the Environment and the Welsh Office or the Building Standards (Scotland) (Consolidation) Regulations issued by the Scottish Development Department.
- c) All relevant codes of practice.
- d) The relevant parts of the current editions of the following British Standards:-  
BS 1251  
BS 4543 Part 2  
BS 5440 Part 1  
BS 5440 Part 2  
BS 5871 Part 3  
BS 6461 Part 1  
BS 6891  
BS 8303

In the republic of Ireland the installation must also conform with the relevant parts of:

- a) The current editions of:-  
IS 813  
ICP3  
IS327
- b) All relevant national and local rules in force

**2.2**As supplied the appliance can be installed in the following situations:-

To a fireplace complete with surround and hearth as shown in figure 1 and complying with BS1251. The required fireplace, hearth, and clearance dimensions are shown in figure 1.

Into a fireplace that has a fireback of nominal size 400mm and conforming to BS1251.

Suitable flues and minimum flue sizes are as follows:-

- a) 225mm x 225mm conventional brick flue.
- b) 175mm diameter lined brick or stone flue.
- c) 200mm diameter factory made insulated flue manufactured to BS4543.
- d) 175mm diameter flue pipe. See BS6461 Part 1 for suitable materials.

The minimum effective height of the flue must be 3m.

The flue must not be used for any other appliance or application.

Any chimney damper or restrictor should be removed. If removal is not possible, they must be secured in the open position.

If the appliance is intended to be installed to a chimney which was previously used for solid fuel, the flue must be swept clean prior to installation. All flues should be inspected for soundness and freedom from blockages.

If the fireplace opening is an underfloor draught type, it must be sealed to stop any draughts.

The appliance must be mounted behind a non-combustible hearth (N.B. conglomerate marble hearths are considered as non-combustible). The hearth material must be at least 12mm thick. The periphery of the hearth (or fender) should be at least 50mm above floor level to discourage the placing of carpets or rugs over it. (See fig 1)

The surface of the hearth must be sufficiently flat to enable the bottom of the front surround and the bottom front cover to be aligned horizontally. Any excessive unevenness (uneven tiles, Cotswold stone, etc.) should be rectified.

The appliance must not stand on combustible materials or carpets.

The minimum height from the top of the fireplace opening to the underside of any shelf made from wood or other combustible materials is as follows:-

- *For a shelf up to 150mm deep*  
Minimum height = 200mm.
- *For a shelf deeper than 150mm*  
200mm + 12.5mm for every 25mm depth over 150mm.

Note that soft wall coverings (e.g. embossed vinyl, etc.) are easily affected by heat. They may scorch or become discoloured when close to a heating appliance. Please bear this in mind when installing.

This appliance must not be installed in any room which contains a bath or shower or where steam is regularly present. An extractor fan may only be used in the same room as this appliance, or in any area from which ventilation for the appliance is taken, if it does not affect the safe performance of the appliance. Note the spillage test requirements detailed further on in this manual. If the fan is likely to affect the appliance, the appliance must not be installed unless the fan is permanently disconnected.

In the UK no special ventilation bricks or vents are normally required in the room for this appliance.

In the Republic of Ireland permanent ventilation must comply with the rules in force.

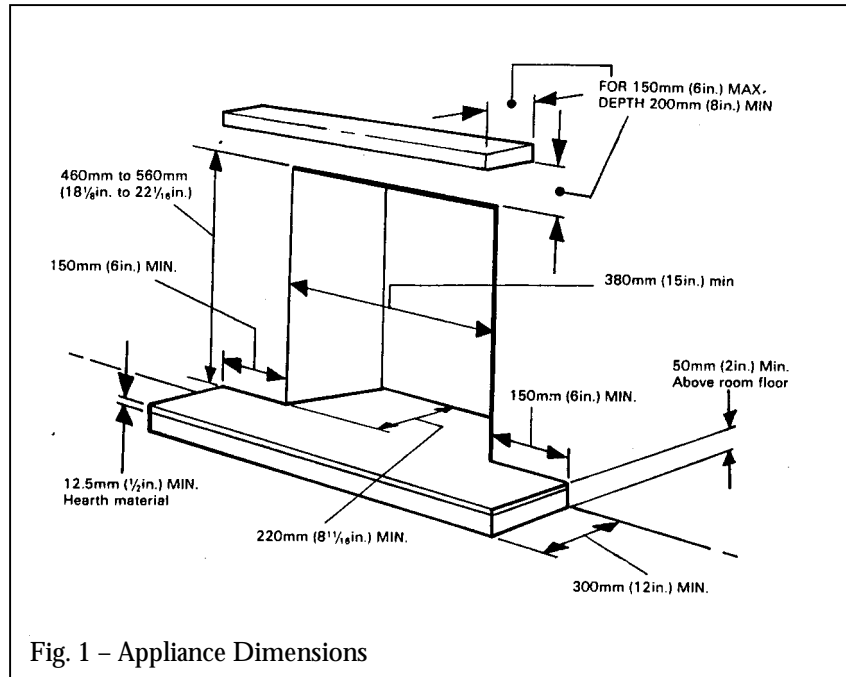

### 3. UNPACKING

Contents:

- 1 Burner assembly
- 1 Nut & olive for 8mm inlet pipe
- 2 Front coals ( 1 x right hand 1x left hand )
- 1 Coal matrix
- 1 Coal matrix support plate & Fasteners
- 1 Pack of loose coals containing 14 coals
- 1 Users instruction booklet
- 1 Firefront and Cover
- 1 Inner Fixing Bracket & Fasteners

Carefully remove the contents . Take special care in handling the ceramic components and the coals. Check that all the listed parts are present and in good condition.

### 4. INSTALLATION OF APPLIANCE

#### INSTALLATION

##### Fireplace size

The fireplace must comply with the requirements described in section 2.

##### Fireplace flue pull.

Visually inspect the flue for any obstruction , and that a smooth transition from the fireplace opening into the flue is available. Carry out a flue flow test by using a smoke pellet within the fireplace opening. Observe the smoke. If there is a definite flow into the opening continue with the installation. If there is not a definite flow, preheat the chimney for a few minutes and recheck If there is still no definite flow, the chimney may need attention. ***Do not fit the appliance. Seek expert advice.***

##### Flue Termination

If fitted any termination used shall not restrict the exit and safe dispersal of the combustion products from the flue and shall have outlet openings on all sides or all round the terminal. The total free area of the outlet openings shall be at least twice the nominal area of the flue. See BS 5871 pt 3 1991.

## **Installation of the burner unit**

Prior to installation of the burner the coal matrix support plate must be fitted. See fig 2 the plate is retained by two self tapping screws. **Failure to fit the support plate will prevent the correct placement of the fuel bed components.**

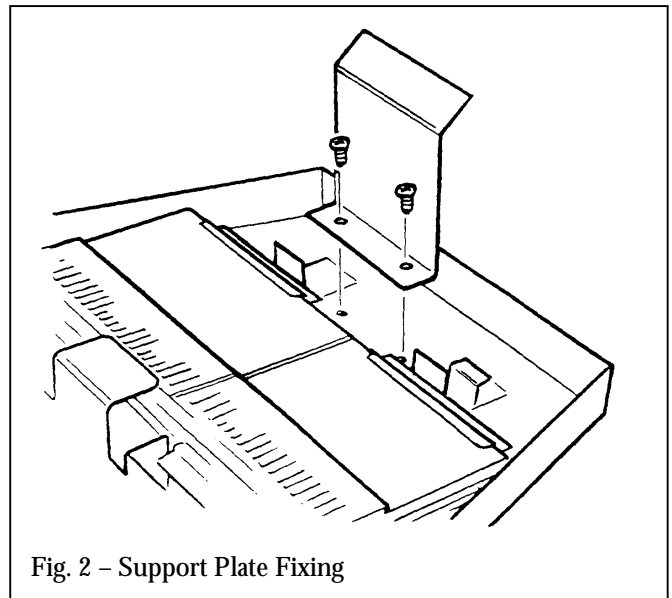

Fig. 2 – Support Plate Fixing

## **Burner Positioning**

Place the burner unit centrally within the fireplace opening. See Fig.3. Position the burner to the rear of the opening, this may be extended forward by a maximum of 25mm providing the front of the burner tray does not protrude beyond the front plane of the fireplace opening.

The burner unit can be fixed in the fireplace in two alternative ways. Method 1 ( see fig 3a ) is the simplest but if the hearth is such that the drilling a fixing hole in the hearth would be difficult or unsightly method 2 ( see fig 3b ) should be employed.

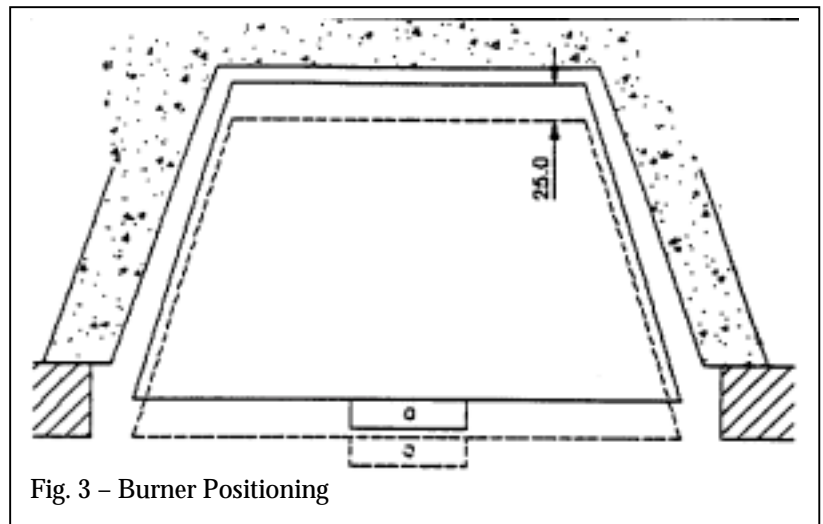

Fig. 3 – Burner Positioning

### *Method 1*

- Place the burner assembly in the position.
- Mark on the hearth the position of the fixing hole at the bottom front of the front leg.
- Remove the burner assembly.
- Using a 6mm masonry drill , drill into the hearth at the marked position.
- Insert the supplied rawlplug.
- Replace the burner assembly and fix in position using the woodscrew provided.

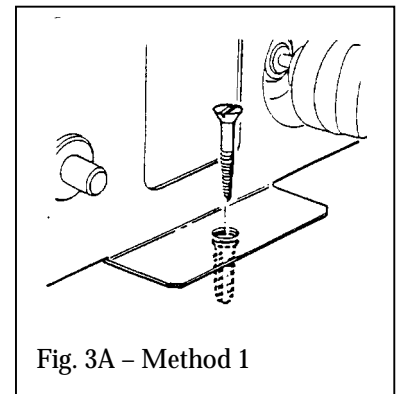

Fig. 3A – Method 1

### *Method 2*

- Place the burner assembly in the position.
- Mark on the fireplace floor the position of one of the fixing holes in the bracket which will require attachment to the front leg see fig 3b. There are two holes in this bracket to allow the soundest and most even surface of the fireplace floor to be used for fixing.
- Remove the burner assembly.
- Using a 6mm masonry drill , drill into the hearth at the marked position.
- Insert the supplied rawlplug.
- Remove the fixing bracket from the front leg by undoing the screw and nut.
- Place the bracket in position on the fireplace floor and fix in position using the woodscrew provided.
- Place the burner assembly back in position and attach to the bracket by refitting the nut and screw.

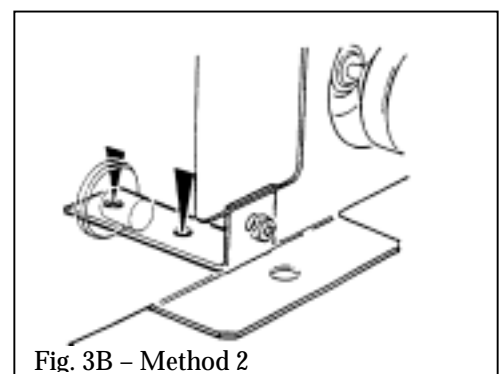

Fig. 3B – Method 2

A nut and olive is provided for an 8mm pipe inlet connection directly to the gas control. The supply pipe must be rigid material. Flexible pipe must not be used. The appliance includes an isolating elbow to facilitate connection and subsequent servicing. Connect the supply line to the appliance. Pressure check the installation pipework for gas soundness in accordance with the current edition of BS6891.

### **Preliminary burner checks.**

Some burner operations can be checked at this stage. Checking now will mean that less disassembly will be required if any problems are found. ***A full check should still be made, however, after final installation.***

If closed, open the isolating valve fitted to the supply line to the appliance. Rotate the control to the pilot position and depress. Press the piezo button repeatedly. There may be a delay before the pilot lights due to air being purged from the system.

When the pilot burner is operating properly, gradually turn the control knob anti-clockwise to HIGH (Depress the knob slightly to get past the LOW position). The main burner should now light. Depress the control knob slightly to release from the HIGH position and turn back (clockwise) to LOW. While turning, the burner flames should gradually become lower but remain alight. Depress the control knob slightly to release from the LOW position and turn back (clockwise) to IGN. The main burner should extinguish but the pilot should remain alight. Depress the control knob slightly and turn back (clockwise) to turn OFF this will extinguish the pilot.

### **Check reference pressure.**

The appliance is pre-set to give the correct heat input at the inlet pressure shown within Appliance data section of this manual. No further adjustment is necessary. The burner pressure should be checked by fitting a pressure gauge at the test point accessible through the aperture in the front leg. (see fig 4). The pressure should be checked with the appliance alight and the control set at HIGH. After checking the pressure, turn off the appliance. Remove the pressure gauge and replace the test point sealing screw. Re-light the appliance. Turn to HIGH position and test around the sealing screw for gas soundness using a suitable leak detection fluid.

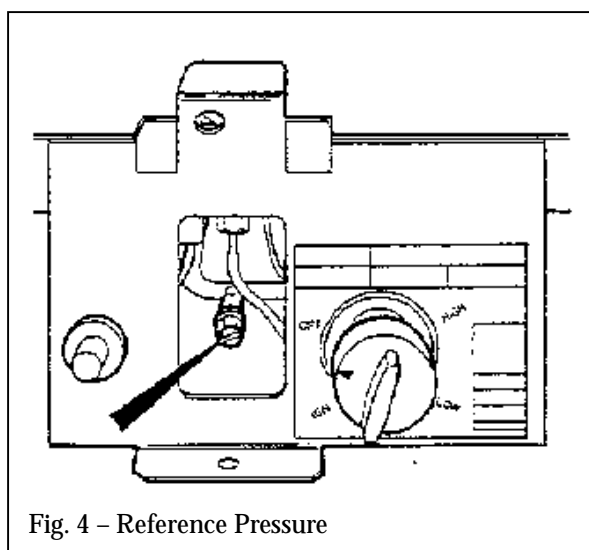
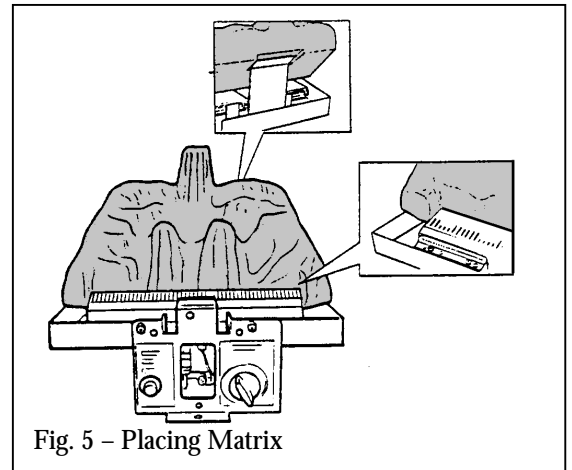

Fig. 4 – Reference Pressure

## 5. INSTALLING THE FUEL BED COMPONENTS

### Placement of the ceramic coal matrix.

Position the bottom rear face of the coal matrix resting on the angled ledge of the coal matrix support plate located towards the back of the burner tray. The bottom front edge of the coal base should locate behind the recess in the burner plaques (See figure 5).



Place the ceramic front coals in position in front of the coal matrix. Make sure that the side legs of the front coals are fully seated into the burner tray. (See figure 6).

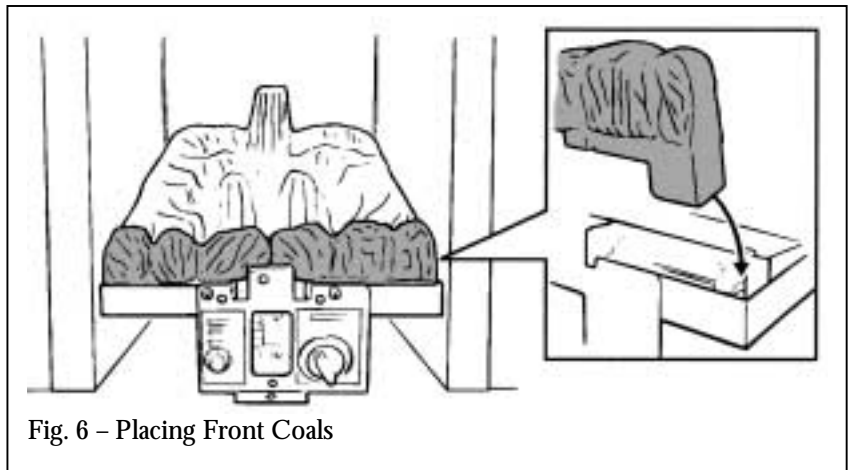

Install the 14 loose coals as follows. Place 5 of the coals resting between the front coal and the coal matrix. Please note the coals should bridge across the front coal to the coal matrix not placed in between. (See figure 7).

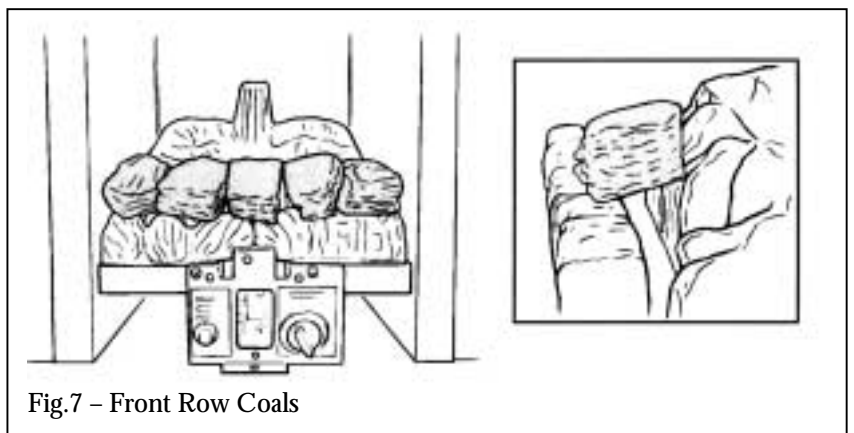

Place a single coal upon the two peaks of the coal matrix directly behind the centre line of the first row of coals. (see figure 8).

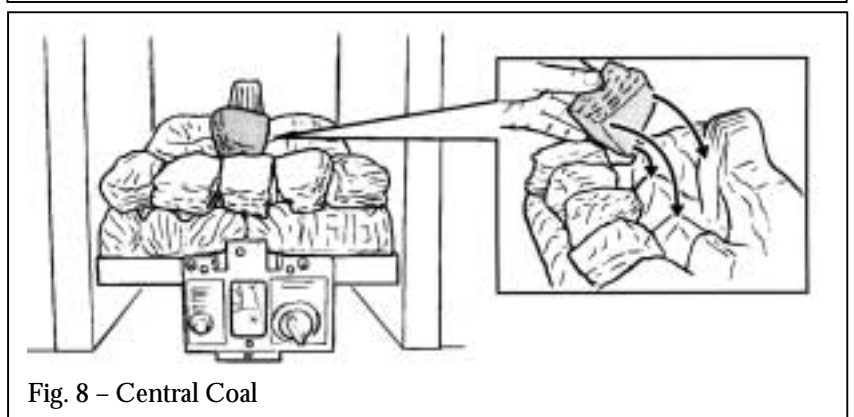



Place four further coals, two each side of the centre coal directly behind the front row of coals ( see figure 9)

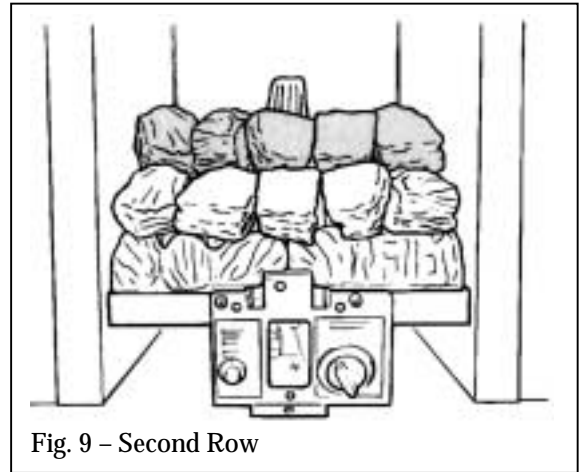

Fig. 9 – Second Row

Place the remaining four coals behind the second row of coals , two each side of the centre coal shape formed within the matrix. ( see figure 10 )

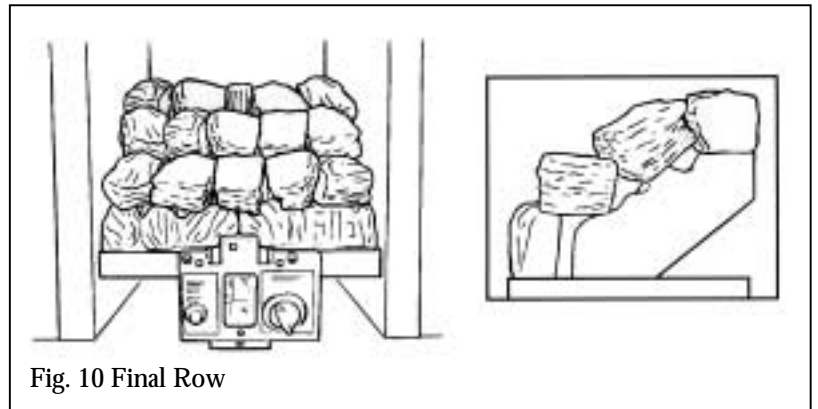

Fig. 10 Final Row

## 6. FULL OPERATING CHECKS

### Decorative firefront.

Place the decorative firefront on the hearth and central to the appliance.

### Spillage check.

***A spillage check must be made before leaving the installed appliance with the customer. Make this with all the ceramic coals in position. ( see fig 11 )***

Close all doors and windows in the room containing the appliance. Light the appliance and set the control to the maximum position. Leave the appliance on for five minutes. See lighting instructions within Installation of Appliance section.

Insert the smoke match at least 50mm away from the side of the fireplace opening and not more than 50mm from the top of the opening.

The installation is satisfactory if the smoke is drawn into the fireplace opening. If the smoke is not drawn into the fireplace opening, leave the appliance alight at the HIGH setting for a further ten minutes and then repeat the test. If smoke is still not drawn into the appliance ***Disconnect the appliance and seek expert advice.***

If the above test is satisfactory, open all internal connecting doors, hatches, etc. in the room. Keep all doors and windows that open to the outside of the building closed. Switch on any extractor fan installed in the same room as the appliance or a connecting room. Open all doors and other openings between the fan and the appliance. Recheck for spillage as above. If the smoke is drawn into the appliance, continue with the installation. If the test is not satisfactory, ***Disconnect the appliance and advise the customer of the cause of failure***

### Final commissioning

Visually inspect the appliance. Clean off any marks incurred during installation.

Hand these instructions and the user's instructions to the customer.

Advise the customer that they should read their Owner's guide before operating the fire and always follow the advice in the section headed "Cleaning".

***Stress that no extra coals must be added over and above those supplied with the appliance and that any replacements must only be the authorised spares. Warn that ignoring this advice could cause incomplete clearance of the products of combustion with consequent health hazards.***

Advise the customer how to operate the appliance. Point out that lighting instruction details are contained within the user's instructions.

Explain that this appliance is fitted with a atmosphere sensing device , ODS pilot unit , which will automatically shut off the supply of gas to the fire if, for any reason, the flames go out It will also shut off the gas supply if the flue is blocked or if there is not enough ventilation. If this device does operate or if the fire is turned off accidentally or intentionally, always wait three minutes before attempting to relight.

Advise the customer that the fire front and ceramic pieces can be cleaned as described in the user's instructions and that the coal pieces must be replaced as described in those instructions.

Recommend that the appliance should be serviced and the chimney inspected by a competent person at least annually.

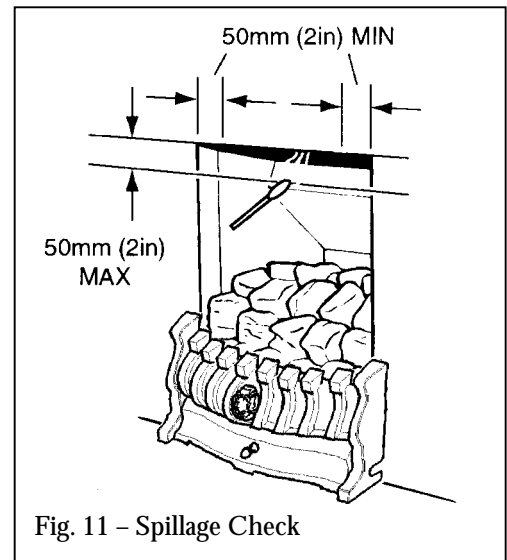

## 7. SERVICING & PARTS REPLACEMENT

- ***Always turn off the gas supply before commencing any servicing (The inlet elbow for this appliance incorporates an isolating valve).***
- ***This product uses fuel effect pieces, burner compartment walls and gaskets containing Refractory Ceramic Fibres (RCF), which are man-made vitreous silicate fibres. Excessive exposure to these materials may cause temporary irritation to eyes, skin and respiratory tract. Consequently, it makes sense to take care when handling these articles to ensure that the release of dust is kept to a minimum. To ensure that the release of fibres from these RCF articles is kept to a minimum, during installation and servicing we recommend that you use a HEPA filtered vacuum to remove any dust and soot accumulated in and around the fire before and after working on the fire. When replacing these articles we recommend that the replaced items are not broken up, but are sealed within a heavy duty polythene bag, clearly labelled as RCF waste. This is not classified as “hazardous waste” and may be disposed of at a tipping site licensed for the disposal of industrial waste. Protective clothing is not required when handling these articles, but we recommend you follow the normal hygiene rules of not smoking, eating or drinking in the work area and always wash your hands before eating or drinking.***
- ***Always turn off the gas supply and allow the appliance to cool down before commencing any servicing or replacement of parts.***
- Check that the appliance is clean and that soot or debris is not blocking the gaps between the coals causing an imperfect flame.
- Check that soot or debris is not impairing the electrode spark or pilot burner.
- Check that soot or debris is not blocking any of the slots in the main burner.
- After servicing, make sure that the ceramic components and coals are replaced correctly as described in the installation instructions.
- ***Always test for gas soundness and spillage after servicing the appliance***

### TO REMOVE THE BURNER UNIT

- Remove the firefront and place in a safe position..
- Remove the 14 loose coals, the front coals and the coal matrix.
- Disconnect the appliance from the inlet connection of the gas tap.
- Dependent upon which method of burner fixing was chosen remove the front leg fastening screw if fitted or remove the retaining bracket retaining bolt from the front leg.
- Replace in the reverse order.

### TO REMOVE THE ODS PILOT UNIT

- Remove the burner unit - See above.
  - Detach the electrode lead from the underside of the electrode tab.
  - Disconnect the pilot pipe from the pilot unit.
  - Remove the tap retaining nut from the front leg.
  - Remove two screws securing the front support to the burner tray.
  - Withdraw the front support and ODS pilot assembly from the tray.
  - Remove two screws securing the pilot support bracket to the front support.
  - Remove the screw securing the dust cage to the pilot unit. Carefully remove the dust cage and place aside.
  - Remove the screw securing the pilot unit to the burner. Remove the pilot unit and place it aside.
  - Refit in the reverse order.
- Once removed, ensure that the dust cage is cleaned before refitting. Make sure that it locates squarely onto the pilot unit without any gaps between the cage edges and the pilot unit.*

## TO REMOVE THE GAS TAP / FSD.

- Remove the burner unit - See above.
- Detach the thermocouple from the gas tap end.
- Undo inlet pipe nut from gas tap.
- Unscrew pipe support clamp and place pipe, clamp and screw aside.
- Remove the main burner supply pipe from the gas tap.
- Remove the pilot burner supply pipe from the gas tap.
- Remove the control knob.
- Detach the tap retaining nut from the front leg and remove the tap/ FSD.
- Refit in the reverse order.

## TO REMOVE THE MAIN BURNER INJECTOR

- Remove the burner unit - See above.
- Disconnect the main burner pipe from the injector at the venturi end. If necessary, loosen the pipe at the gas tap / fsd end to swing the pipe clear of the injector.
- Unscrew the injector from the rear support bracket.
- Refit in the reverse order.

## TO REPLACE BURNER PLAQUES

- Remove the 14 loose coals, the front coals and the coal matrix.
- The plaques can be then be removed as follows.
- Remove the plaque clamping strips by detaching 8 screws.
- Remove the plaques, centre gasket and bottom gasket.
- Fit a new bottom gasket.
- Place the new left hand plaque in position. The left side of the plaque must touch the inside edge of the retaining flange at the left side of the burner well. ***It is important that the plaque is accurately positioned so that it has the correct relationship to the pilot - See figure 12***
- Fit the rear clamping strip over the left hand plaque and partially tighten with two screws.
- Fit the front clamping strip over the left hand plaque and partially tighten with two screws.
- Fully tighten the rear clamping strip then fully tighten the front strip.
- Place the new right hand plaque in position. Fit a new centre gasket between the plaques. Push the plaque and gasket firmly to the left squeezing the gasket between the two plaques. There should be a gap between the right side of the plaque and the edge of the retaining flange at the right side of the burner well.
- Fit the rear clamping strip over the right hand plaque and partially tighten with two screws.
- Fit the front clamping strip over the right hand plaque and partially tighten with two screws.
- Fully tighten the rear clamping strip then fully tighten the front strip.
- Refit the coals as described in the installation instructions.

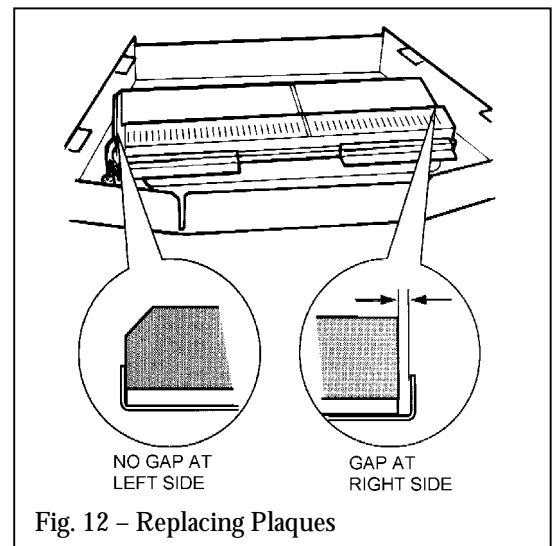

Fig. 12 – Replacing Plaques

## TO REMOVE THE PIEZO UNIT.

- Remove the HT lead from the rear of the piezo unit .
- Remove the piezo retaining nut from behind the front leg.
- Replace in reverse order.

### SHORT LIST OF SPARES

<b>DESCRIPTION</b>	<b>NO. OFF</b>	<b>MAKER'S PART NO.</b>
Pilot unit	1	563309
Burner injector	1	518759
Piezo unit	1	0554909
Burner plaque & gasket set	1	541119
Coal matrix	1	541249
Front coal RH	1	0563339
Front coal LH	1	0563329
Pack of loose coals	1	0563349
Dust cage	1	567619

### **Safety First.**

Valor fires are CE Approved and designed to meet the appropriate British Standards and Safety Marks.



### **Quality and Excellence.**

#### **At the heart of every Valor fire.**

All Valor fires are manufactured to the highest standards of quality and excellence and are manufactured under a BS EN ISO 9001 quality system accepted by the British Standards Institute.



### **The Highest Standards**

Valor is a member of the Society of British Gas Industries which works to ensure high standards of safety, quality and performance.



### **Careful Installation**

Valor is a Corgi registered company. All our gas fires must be installed by a competent Corgi Registered Installer in accordance with our Installer Guide and should not be fitted directly on to a carpet or floor of combustible material.



Valor Heating, Erdington, Birmingham B24 9QP

Because our policy is one of constant development and improvement, details may vary slightly from those given in this publication